

# AMERICAN ACCESS HD25: POST MOUNTED

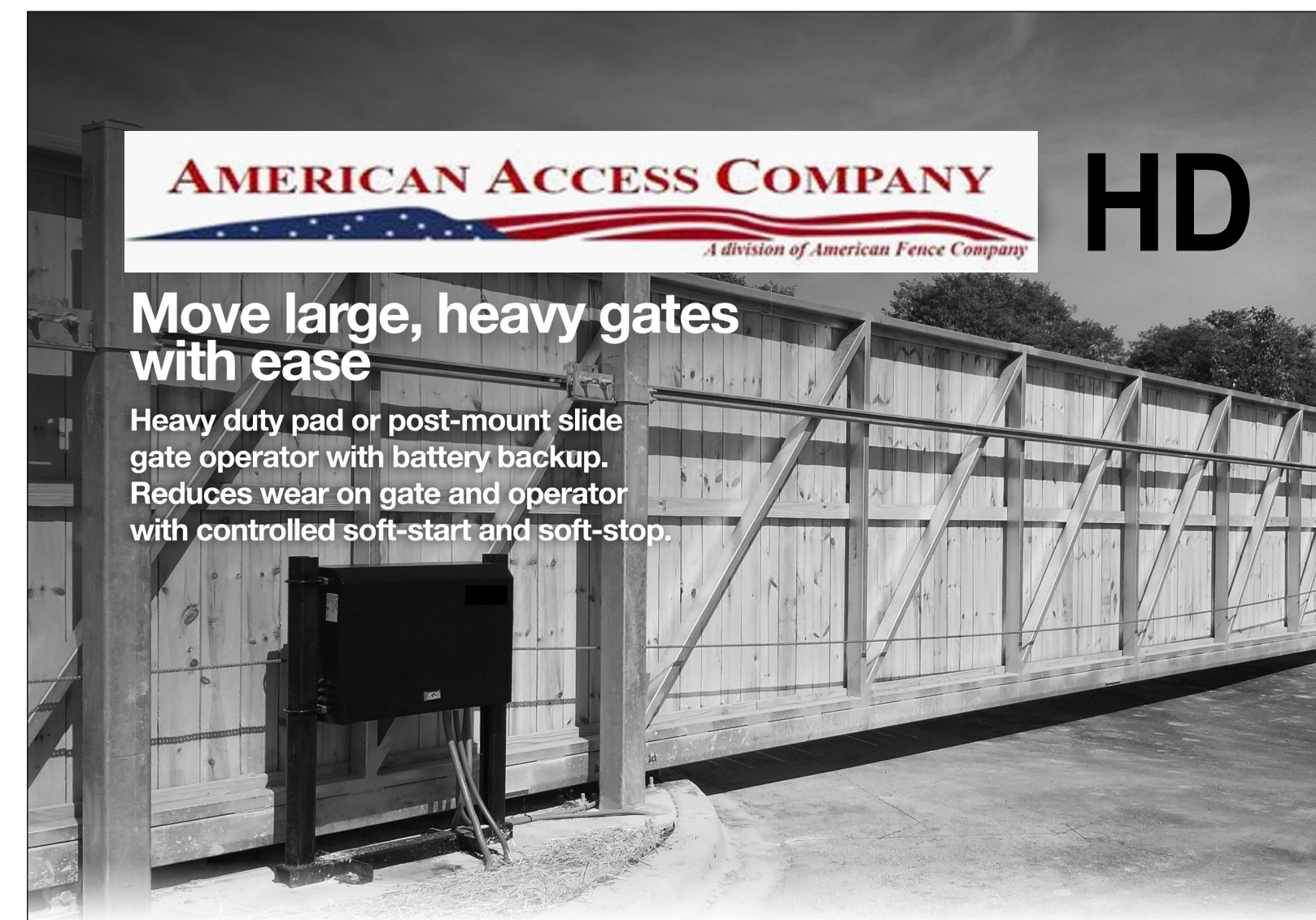
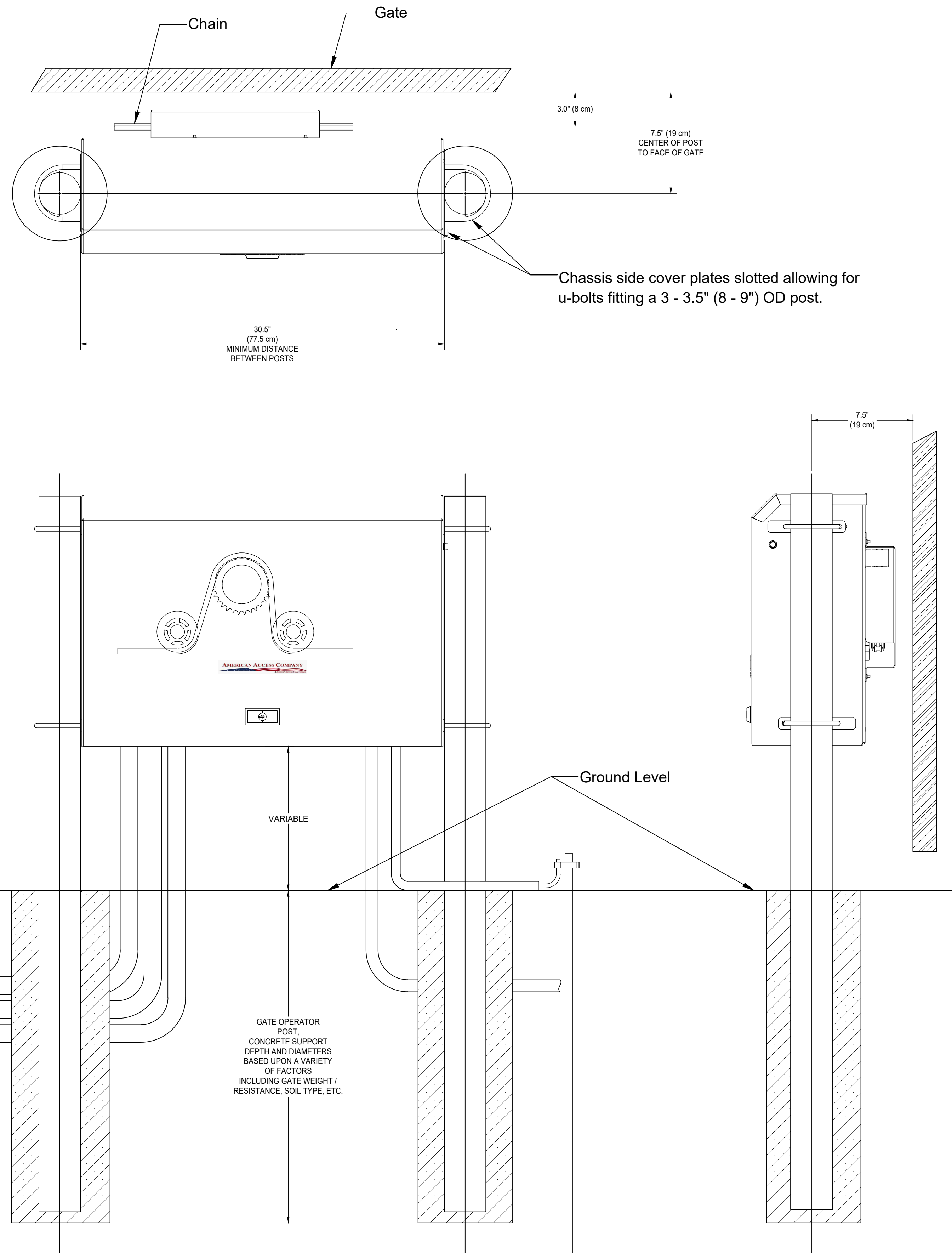

**AMERICAN ACCESS COMPANY** **HD**  
*A Division of American Fence Company*

Move large, heavy gates with ease

Heavy duty pad or post-mount slide gate operator with battery backup. Reduces wear on gate and operator with controlled soft-start and soft-stop.

### Features:

- Weight and length limit:** Move gates up to 3,000 lbs and 50 ft.
- Battery:** Monitor battery conditions and maximize life with the intelligent charging system.
- Design:** Post mount or pad mount all steel rodent resistant enclosure.
- Troubleshooting:** Easy system troubleshooting with onboard event log.
- UPS:** Standard battery backup to keep gates moving up to 100 cycles, with battery upgrades for up to 600 cycles.
- Retrofit:** Easily retrofit similar profile operators out-of-the-box.
- Programmable:** Over 70 user configurable settings to meet site specific requirements.
- MADE IN THE USA:** Designed, tested and built within USA from globally sourced materials.
- Speed:** HD15F cycles in half the time as standard operators.



**AMERICAN ACCESS COMPANY** **HD**  
*A Division of American Fence Company*

Move large, heavy gates with ease



### Technical Specifications

Model	American Access HD15F	American Access HD25	American Access HD30
Duty Cycle	Continuous		
Drive	Electromechanical		
Rate of Travel	1.75, 2 or 2.25 ft/s (53, 61 or 69 cm/s)** Open/Close speed set independently	0.75, 1 or 1.25 ft/s (23, 30 or 38 cm/s)** Open/Close speed set independently	
Gate Length Max.	50 ft (15 m)		
Gate Weight Max.	1,500 lb (680 kg)	2,500 lb (1,134 kg)	3,000 lb (1,361 kg)
Pull Force	300 lb	450 lb*	500 lb*
UPS Battery Backup Cycles	Field configurable to fail open or secure when batteries deplete. Standard battery backup gate travel: Two 8Ah batteries. Up to 4,000 ft (1,219 m) After AC power loss. Extended battery backup gate travel: Two 50Ah batteries. Up to 25,000 ft (7,620 m) after AC power loss.		
Temperature Rating	-13°F to 158°F (-25°C to 70°C) No heater necessary.		
Operating Voltage	24VDC		
Input Voltage	115V or 208-230V 50/60Hz		
Accessory Power	12VDC and 24VDC 1A each		
Included Accessories	30 ft (9 m) of #40, corrosion resistant roller chain and two steel gate mounting brackets, one premium EMX (RB-MON) photo eye, one 5-foot premium ASO edge sensor, and a pre-wired Hy2Relay adapter.		
Communication	USB, RS-232, RS-485		
User Controls	Smart DC Controller with 70+ configurable settings, 32 character LCD display and 5 tact buttons or a PC using S.T.A.R.T. software.		
Relays	Two configurable user relays: 30VDC, 3A solid state and 250VAC, 10A electromechanical. Optional Hy2Relay™ for 8 additional relay outputs.		
Finish	Zinc rich primer and black powder coated steel cover/chassis.		
ETL Listed (UL 325)	Usage Class III, IV	USAGE CLASS I, II, III, IV	
Cycle Tested	500,000 cycles		
Warranty	5 year (7 year single-family residential) w/product registration		

\* Speed setting cannot be configured to exceed 1 ft/s FOR Usage Class I and II.  
 \*\* The actual number of gate cycles available from battery depends upon gate resistance to travel, cycle length, battery size, state of charge and health, ambient temperature, accessory power draw and frequency of gate cycles during power outage.



The American Access Company brand provides high-quality, ultra-reliable industrial gate operators and crash-rated, Hostile Vehicle Mitigation (HVM) Vehicle barriers designed to secure and protect critical infrastructure and facilities nationwide.

americanaccesscompany.com

OPERATOR	AMERICAN ACCESS HD 25 GATE OPERATOR
DUTY CYCLE	CONTINUOUS
POWER, 1Ø	SWITCH SELECTABLE 115 V SINGLE PHASE OR 240 V SINGLE PHASE
MOTOR	1 hp
GATE SPEED	11 in/s (28 cm/s)
GATE WEIGHT	MAXIMUM 2,000 lbs (907 kg)

REV	DESCRIPTION	DATE



CHAIN LINK DOUBLE TRACK ALUM. CANT. GATE W/ AMERICAN ACCESS COMPANY HD25 GATE OPERATOR

PALMSHIELD PROJECT #	CLIENT
REFERENCE DWG BY DATE	RETURN DWG BY DATE
CHKD BY	DRAWN BY
SCALE: 1-1/2" = 1'-0"	DATE: 02/16/2024
REV	SHEET # 01



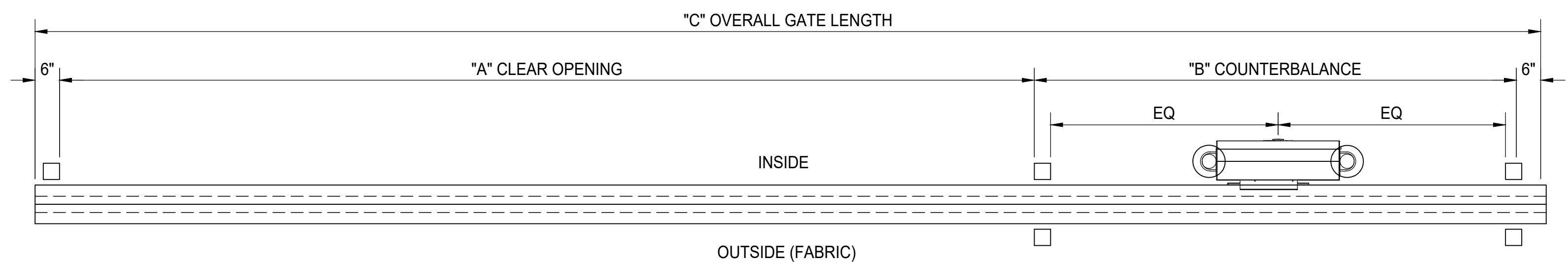

**PLAN VIEW**

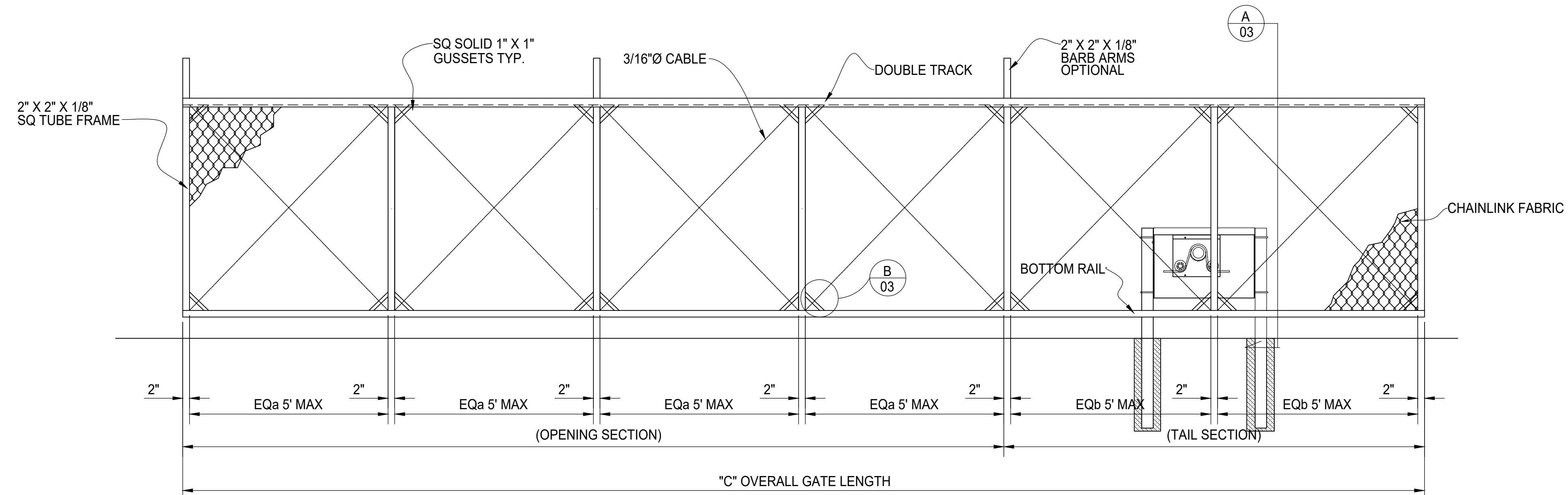

**ELEVATION VIEW ALUMINUM CANTILEVER GATE  
OUTSIDE LOOKING IN**

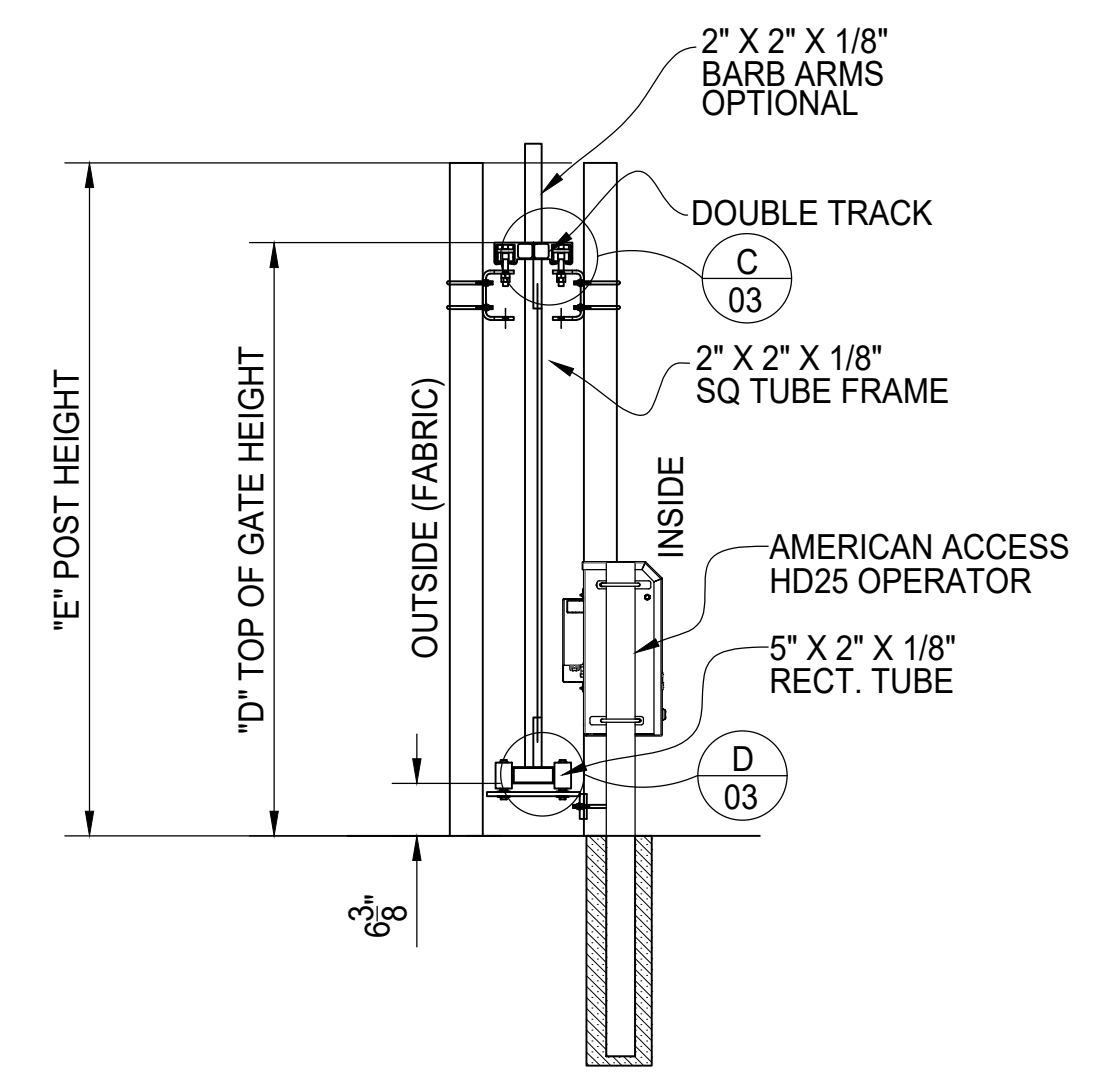

**A SECTION**

CRITICAL DIMENSIONS			
	DESCRIPTION	FORMULA	DIMENSION
"A"	CLEAR OPENING	A	
"B"	COUNTERBALANCE	A/2	
"C"	OVERALL GATE LENGTH	A + B + 12"	
"D"	TOP OF GATE HEIGHT	D	
"E"	POST HEIGHT	E	
ADJOINING FENCE HEIGHT			
BARB ARMS REQUIRED		YES	NO
GATE STORAGE IN OPEN POSITION (OUTSIDE LOOKING IN)		LEFT (SHOWN)	RIGHT

OPERATOR	AMERICAN ACCESS HD 25 GATE OPERATOR
DUTY CYCLE	CONTINUOUS
POWER, 1Ø	SWITCH SELECTABLE 115 V SINGLE PHASE OR 240 V SINGLE PHASE
MOTOR	1 hp
GATE SPEED	11 in/s (28 cm/s)
GATE WEIGHT	MAXIMUM 2,000 lbs (907 kg)

REV	DESCRIPTION	DATE

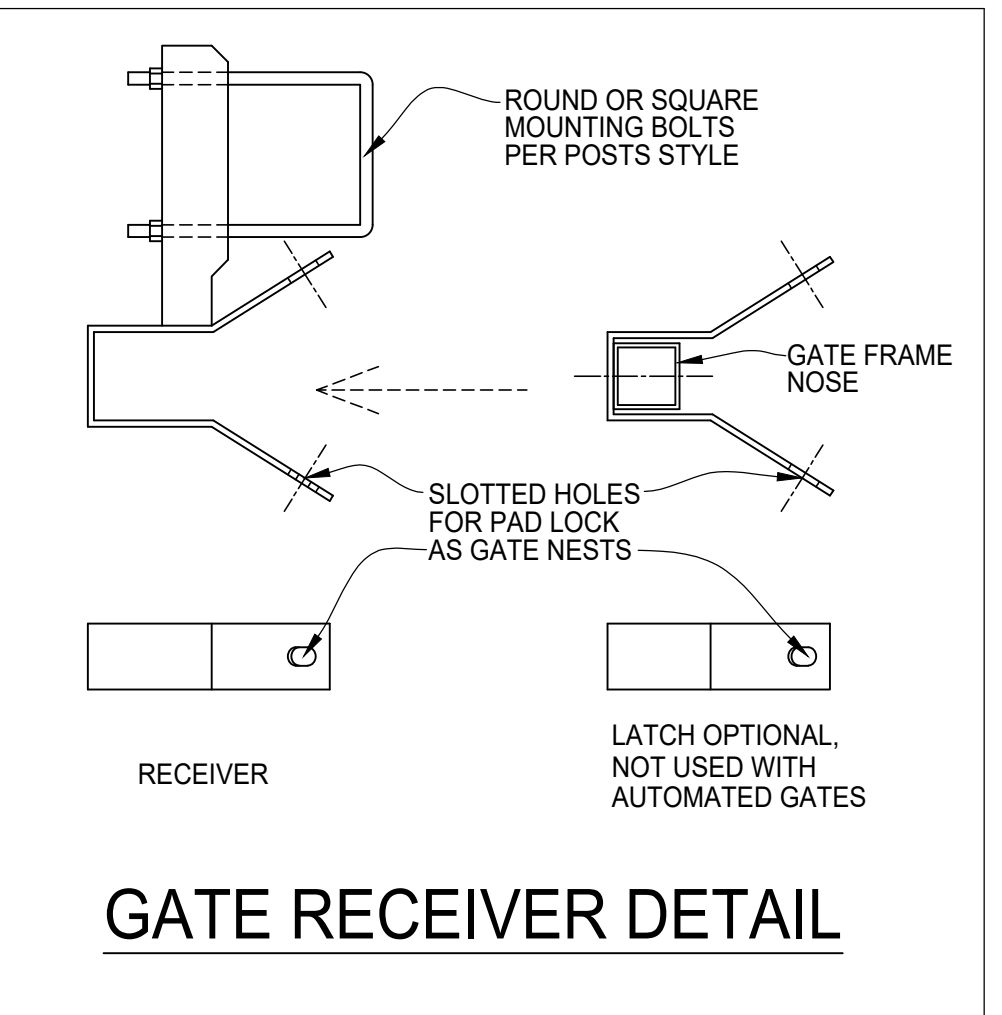
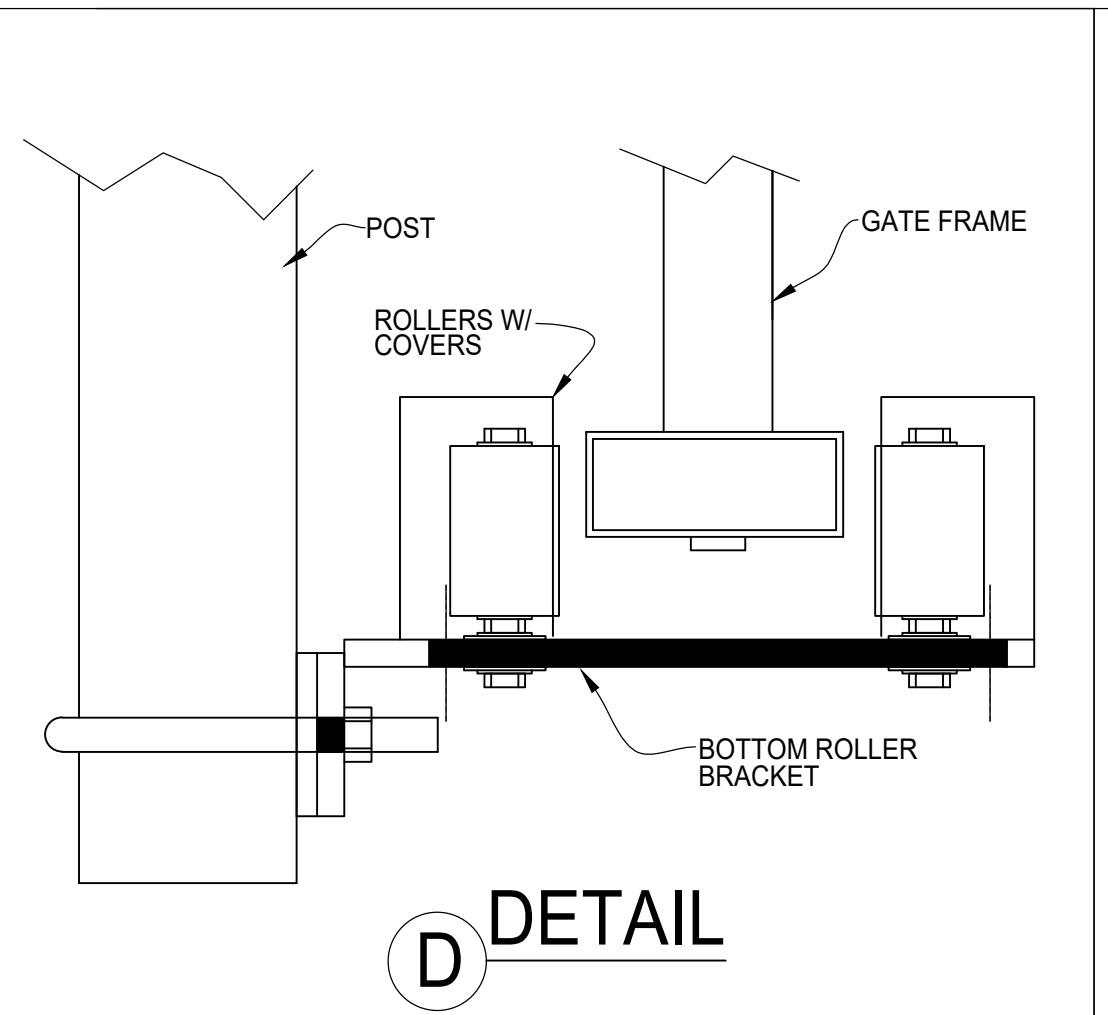
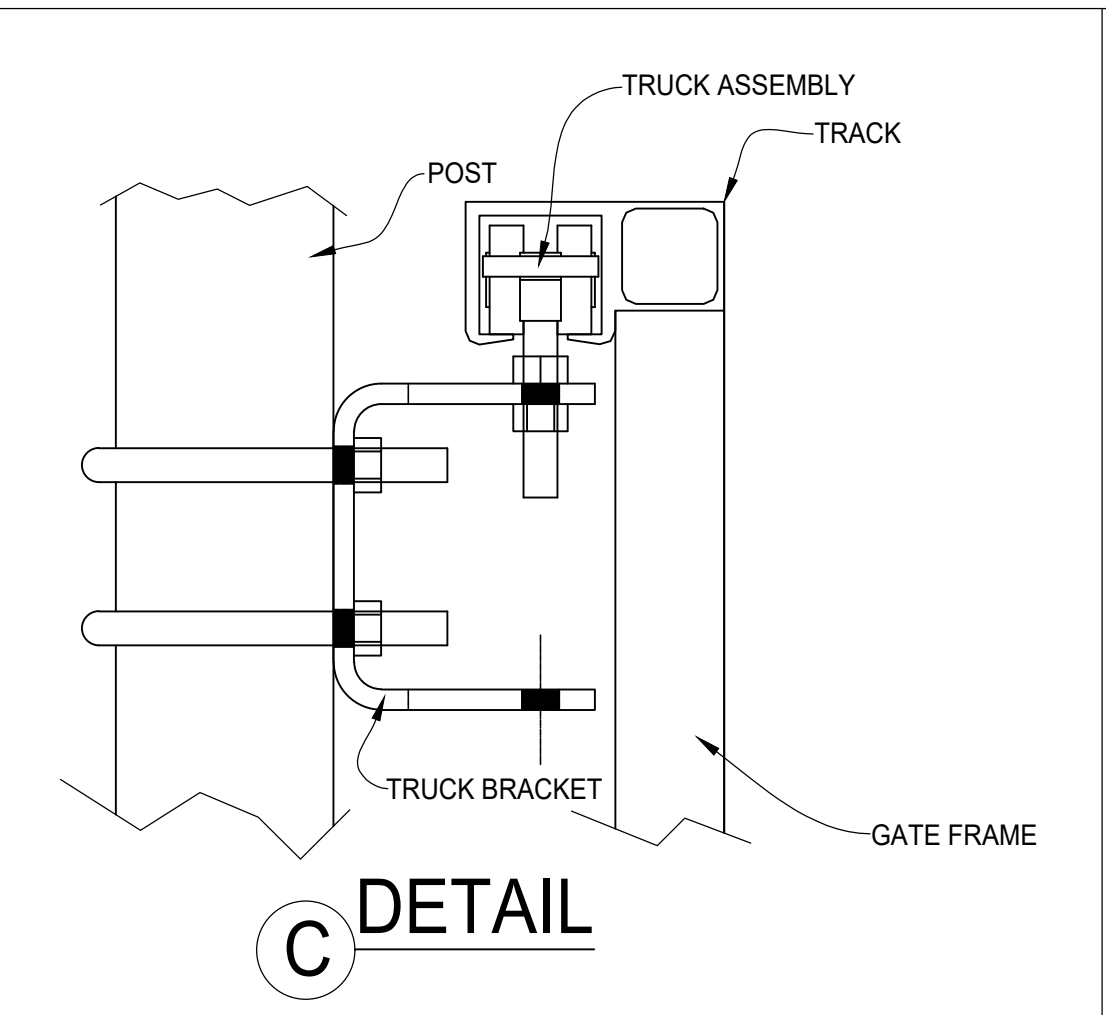
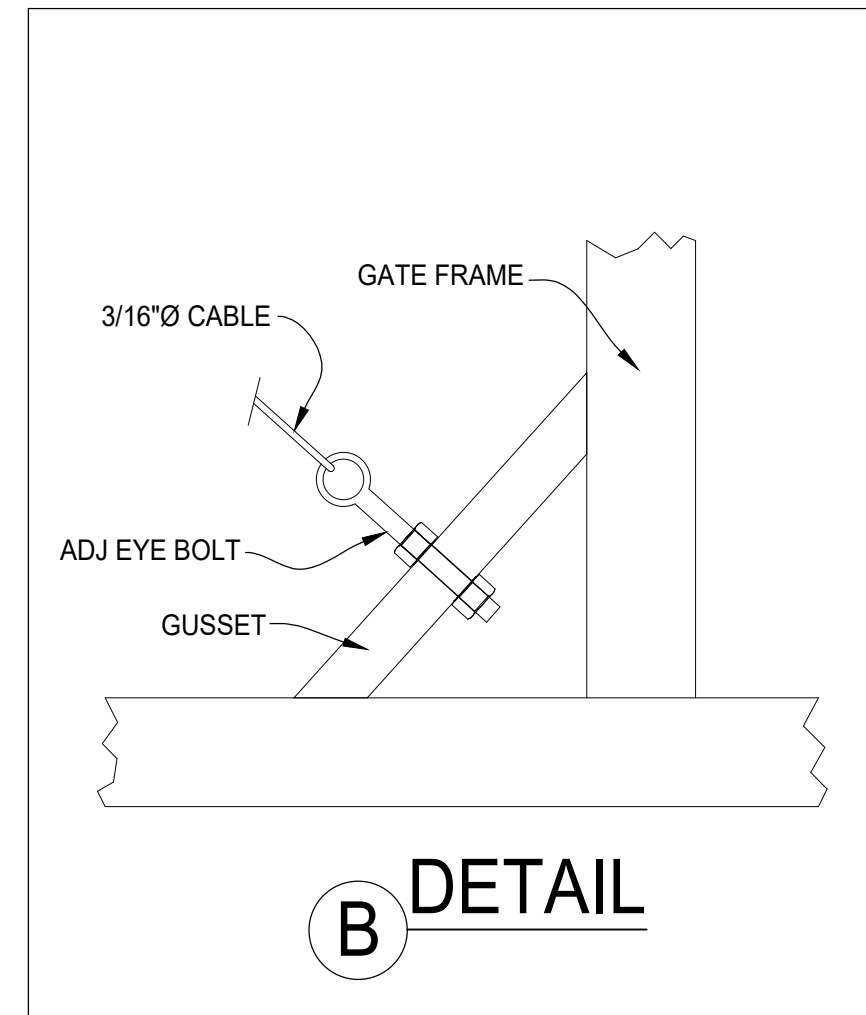

**CHAIN LINK  
DOUBLE TRACK ALUM. CANT. GATE  
W/ AMERICAN ACCESS COMPANY  
HD25 GATE OPERATOR**



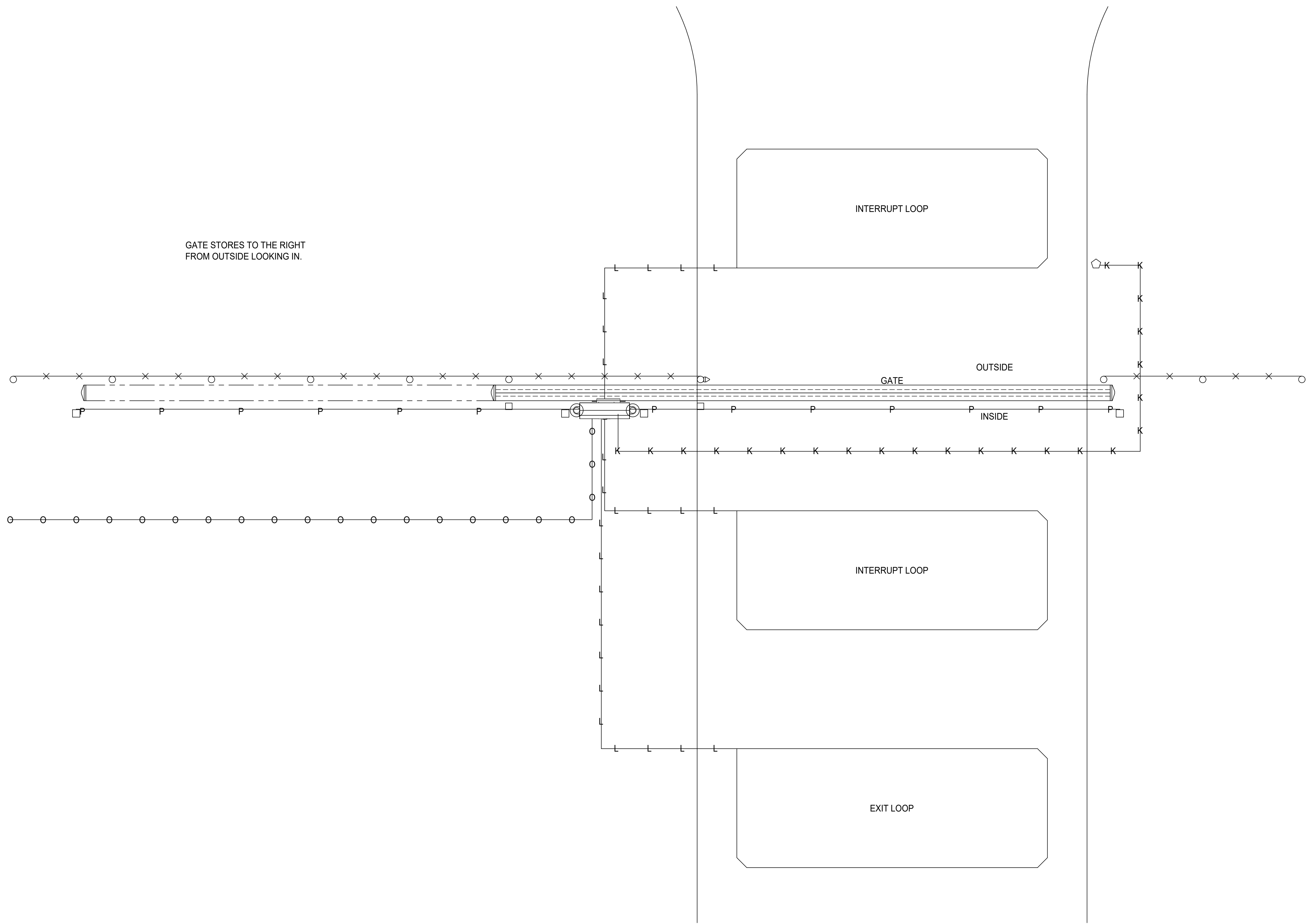

GATE STORES TO THE RIGHT  
FROM OUTSIDE LOOKING IN.

LEGEND

	AMERICAN ACCESS HD25 OPERATOR
	LINEAR AK11 SURFACE MOUNT KEYPAD
	EMX-THRU-BEAM PHOTO EYE
	EMX-WEL-200 EDGE SENSOR
	LOW VOLTAGE 12V AND 24V ACCESSORY WIRING
	LOW VOLTAGE 12V AND 24V ACCESSORY WIRING
	LOW VOLTAGE 12V AND 24V ACCESSORY WIRING
	HIGH VOLTAGE 115/240V SUPPLY POWER
	FENCELINE
	GATE PATH

OPERATOR	AMERICAN ACCESS HD 25 GATE OPERATOR
DUTY CYCLE	CONTINUOUS
POWER, 1Ø	SWITCH SELECTABLE 115 V SINGLE PHASE OR 240 V SINGLE PHASE
MOTOR	1 hp
GATE SPEED	11 in/s (28 cm/s)
GATE WEIGHT	MAXIMUM 2,000 lbs (907 kg)

REV	DESCRIPTION	DATE



CHAIN LINK SIN. TRACK ALUM CANT. GATE  
W/ AMERICAN ACCESS COMPANY  
HD25 GATE OPERATOR  
ELECTRICAL WIRING REQUIREMENT

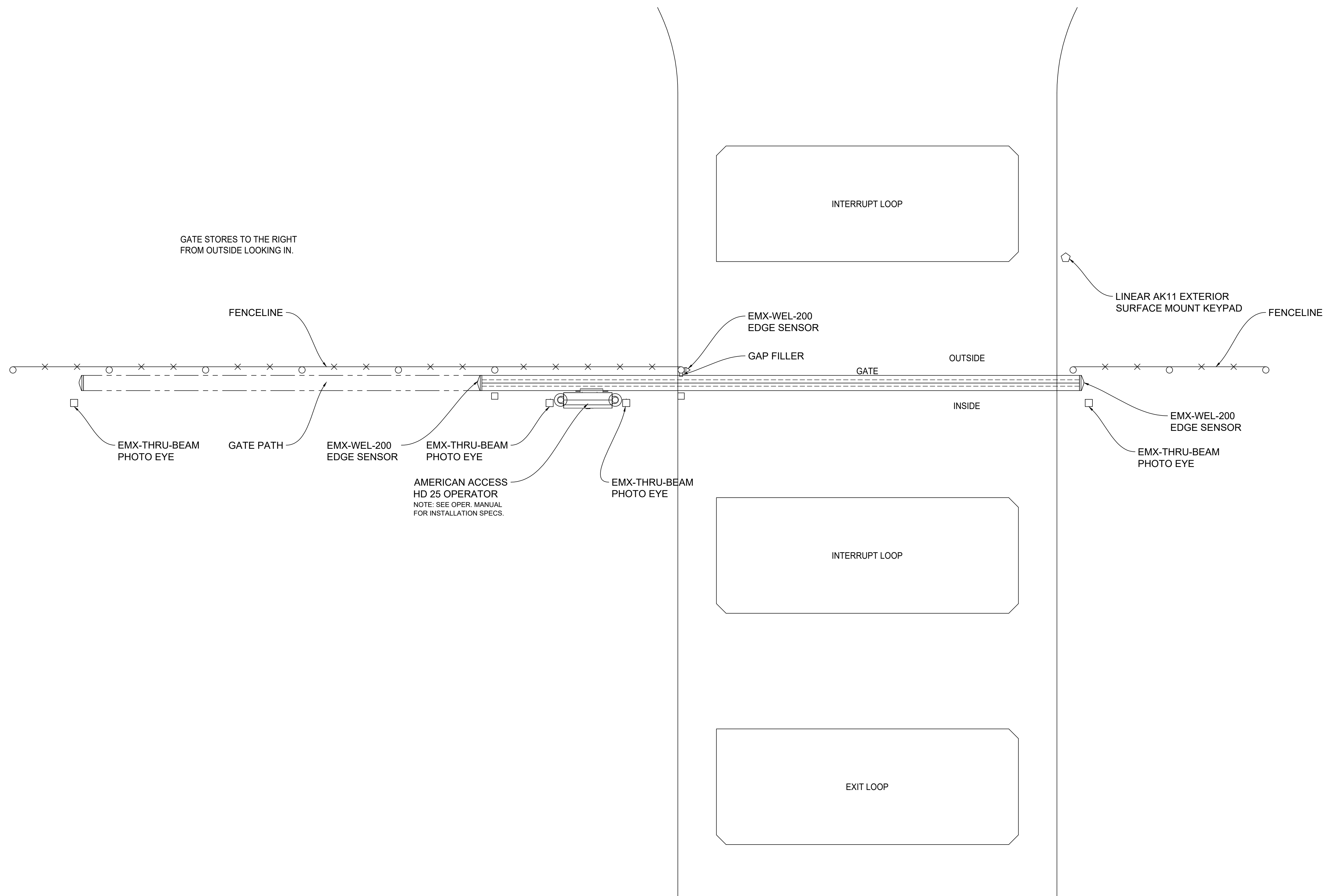

OPERATOR	AMERICAN ACCESS HD 25 GATE OPERATOR
DUTY CYCLE	CONTINUOUS
POWER, 1Ø	SWITCH SELECTABLE 115 V SINGLE PHASE OR 240 V SINGLE PHASE
MOTOR	1 hp
GATE SPEED	11 in/s (28 cm/s)
GATE WEIGHT	MAXIMUM 2,000 lbs (907 kg)

REV	DESCRIPTION	DATE



**CHAIN LINK SIN. TRACK ALUM CANT. GATE  
W/ AMERICAN ACCESS COMPANY  
HD25 GATE OPERATOR  
EQUIPMENT CALL-OUT**



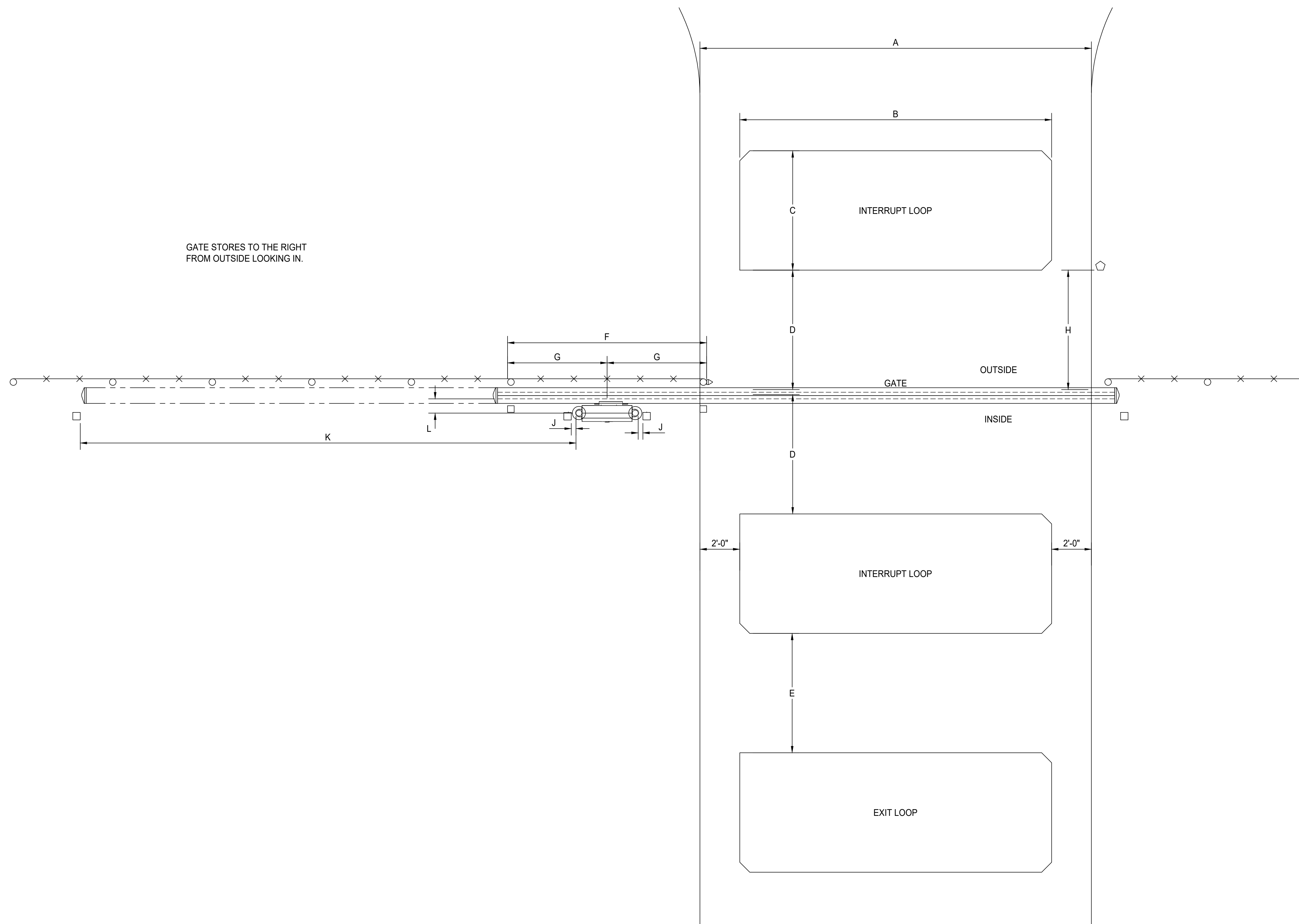

A	DRIVEWAY WIDTH	
B	LONG SIDE OF LOOP WIDTH (A - 4')	
NOTE: CENTERED ON DRIVEWAY		
C	SHORT SIDE OF LOOP WIDTH	
NOTE: COMM. VEH. - 6'; PASS. VEH. - 4'		
D	GATE TO LOOP DISTANCE = C	
E	MINIMUM SPACING = D	
F	OUTSIDE TO OUTSIDE OF POST DISTANCE = 1/2 OF GATE OPENING	
G	CENTER OF OPERATOR (1/2 * F)	
H	KEYPAD MIN. DISTANCE 6'-0"	
J	PHOTOEYE DISTANCE FROM OPERATOR 3" MAXIMUM	
K	PHOTOEYE DISTANCE FROM OPERATOR. PLACED AT END OF GATE PATH INLINE WITH PHOTOEYE	
L	CENTER OF OPERATOR POST DISTANCE TO INSIDE FACE OF GATE	

LEGEND	
	AMERICAN ACCESS HD25 OPERATOR
	LINEAR AK11 SURFACE MOUNT KEYPAD
	EMX-THRU-BEAM PHOTO EYE
	EMX-WEL-200 EDGE SENSOR
	FENCELINE
	GATE PATH

OPERATOR	AMERICAN ACCESS HD 25 GATE OPERATOR
DUTY CYCLE	CONTINUOUS
POWER, 1Ø	SWITCH SELECTABLE 115 V SINGLE PHASE OR 240 V SINGLE PHASE
MOTOR	1 hp
GATE SPEED	11 in/s (28 cm/s)
GATE WEIGHT	MAXIMUM 2,000 lbs (907 kg)

REV	DESCRIPTION	DATE



CHAIN LINK SIN. TRACK ALUM CANT. GATE W/ AMERICAN ACCESS COMPANY HD25 GATE OPERATOR EQUIPMENT LAYOUT

PALMSHIELD PROJECT #	CLIENT
REFERENCE BY DATE	RETURN DWG BY DATE
CHKD BY	SCALE: 3/8" = 1'-0"
DRAWN BY: PB	DATE: 02/16/2024
REV	SHEET # 05